

SIDDHARTH INSTITUTE OF ENGINEERING & TECHNOLOGY:: PUTTUR (AUTONOMOUS)

Siddharth Nagar, Narayanavanam Road – 517583

**QUESTION BANK (DESCRIPTIVE)****Subject with Code: Mechanics of Solids(20CE0164)****Course & Branch: B.Tech (ME&AE)****Year & Sem: II & I****Regulation: R20****UNIT I****(Simple Stresses and Strains, Theories of failure)**

1	a. Define stress and strain and explain their types.	L1	CO1	6M
	b. Draw and explain Stress-strain curve for a mild steel bar.	L1	CO1	6M
2	a. State Hooke's law with equation.	L1	CO1	2M
	b. A tensile test was conducted on a mild steel bar. The following data was obtained from the test : (i) Diameter of the steel bar = 3 cm (ii) Gauge length of the bar = 20 cm (iii) Load at elastic limit = 250 KN (iv) Extension at a load of 150 KN = 0.21 mm (v) Maximum load = 380 KN (vi) Total extension = 60 mm (vii) Diameter of the rod at the failure = 2.25 cm. Determine : (a) The Young's modulus, (b) The stress at elastic limit, (c) The percentage elongation, and (d) The percentage decrease in area.	L3	CO1	10M
3	A brass bar, having cross-sectional area of 1000 mm^2 , is subjected to axial forces as shown in figure. Find the total elongation of the bar. Take $E=1.05 \times 10^5 \text{ N/mm}^2$.	L3	CO1	12M
4	Two brass rods and one steel rod together support a load as shown in fig. If the stresses in brass and steel are not to exceed 60 N/mm^2 and 120 N/mm^2 , find the safe load that can be supported. Take E for steel = $2 \times 10^5 \text{ N/mm}^2$ and for brass = $1 \times 10^5 \text{ N/mm}^2$. The cross-sectional area of steel rod is 1500 mm^2 and of each brass rod is 1000 mm^2	L3	CO1	12M

5	a) Define Bulk Modulus and Poisson's Ratio.	L1	CO1	4M
	b) A steel tube of 30 mm external diameter and 20 mm internal diameter encloses a copper rod of 15 mm diameter to which it is rigidly joined at each end. If, at a temperature of 10°C there is no longitudinal stress, calculate the stresses in the rod and tube when the temperature is raised to 200°C. Take E for steel and copper as $2.1 \times 10^5 \text{ N/mm}^2$ and $1 \times 10^5 \text{ N/mm}^2$ respectively. The value of coefficient of linear expansion for steel and copper is given as $11 \times 10^{-6} \text{ per } ^\circ\text{C}$ and $18 \times 10^{-6} \text{ per } ^\circ\text{C}$ respectively.	L3	CO1	8M
6	A body is subjected to direct stresses in two mutually perpendicular directions accompanied by a simple shear stress. Draw the Mohr's circle of stresses and explain how you will obtain the principal stresses and principal planes.	L2	CO1	12M
7	a) Explain maximum shear stress theory.	L2	CO1	6M
	b) Explain maximum shear strain energy theory.	L2	CO1	6M
8	a) Explain maximum principal strain theory.	L2	CO1	6M
	b) Explain maximum strain energy theory.	L2	CO1	6M
9	At a section of mild steel shaft, the maximum torque is 8437.5 Nm and maximum bending moment is 5062.5 Nm. The diameter of the shaft is 90 mm and the stress at the elastic limit in simple tension for the material of the shaft is 220 N/mm^2 . Determine whether the failure of the material will occur or not according to maximum shear stress theory. If not, then find the factor of safety.	L3	CO1	12M
10	Determine the diameter of a bolt which is subjected to an axial pull of 9 kN together with a transverse shear force of 4.5 kN using : (i) Maximum principal stress theory. (ii) Maximum principal strain theory. (iii) Maximum shear stress theory. (iv) Maximum strain energy theory. Given the elastic limit in tension = 225 N/mm^2 , factor of safety = 3 and Poisson's ratio = 0.3.	L3	CO1	12M

UNIT II

(Shear Force and Bending Moments, Theory of Simple Bending)

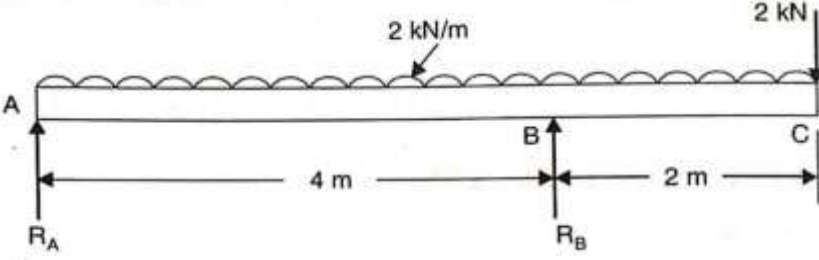
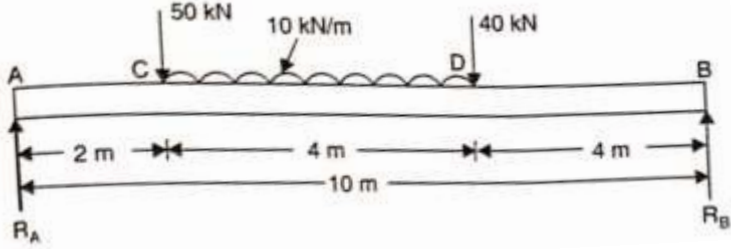
1	A cantilever beam of length 3 m carries a uniformly distributed load of 1.5 KN/m run over a length of 2 m from the free end. Draw SFD and BMD for the beam.	L3	CO2	12M
2	Draw the shear force and bending moment diagram for a simply supported beam of length 9m and carrying a uniformly distributed load of 10 KN/m for a distance of 6 m from the left end. Also calculate the maximum bending moment in the section.	L3	CO2	12M
3	Simply supported beam of length 5 m carries a uniformly increasing load of 800 N/m at one end to 1600 N/m run at the other end. Draw SFD and BMD for the beam. And also calculate the position and magnitude of maximum bending moment.	L3	CO2	12M
4	Draw the shear force and bending moment diagram for overhanging beam carrying uniformly distributed load of 2 KN/m over the entire length and a point load of 2 KN as shown in figure. Locate the point of contra flexure. 	L3	CO2	12M
5	A simply supported beam of length 10m carries the UDL and two point loads as shown in fig. Draw S.F. and B.M. diagram for the beam shown in figure. Also calculate the maximum bending moment. 	L3	CO2	12M
6	a) Derive the simple bending equation.	L2	CO3	6M
	b) A beam is simply supported and carries a uniformly distributed load of 40 KN/m run over the whole span. The section of the beam is rectangular having depth as 500 mm. If the maximum stress in the material of the beam is 120 N/mm ² and moment of inertia of the section is 7 x 10 ⁸ mm ⁴ , find the span of the beam.	L3	CO3	6M
7	a) State the assumptions made in the theory of simple bending.	L2	CO3	6M
	b) A square beam 20 mm x 20 mm in section and 2 m long is supported at the ends. The beam fails when a point load of 400 N is applied at the centre of the beam. What uniformly distributed load per metre length will break a cantilever of the same material 40 mm wide, 60 mm deep and 3 m long?	L3	CO3	6M

8	a) Derive section modulus for rectangular section.	L2	CO3	4M
	b) A beam 500 mm deep of a symmetrical section has $I = 1 \times 10^8 \text{ mm}^4$ and is simply supported over a span of 10 m. Calculate: (i) The uniformly distributed load it may carry if the maximum bending stress is not to exceed 150 N/mm^2 . (ii) The bending stress if the beam carries a central point load of 25 kN.	L3	CO3	8M
9	A cast iron beam is of T-section as shown in figure. The beam is simply supported on a span of 8m. The beam carries a UDL of 1.5kN/m length on the entire span. Determine the maximum tensile and compressive stresses.	L3	CO3	12M
10	A cast iron beam is of I-section as shown in figure. The beam is simply supported on a span of 5 m. If the tensile stress is not to exceed 20 N/mm^2 , find the safe uniform load which the beam can carry. Find also the maximum compressive stress.	L3	CO3	12M

UNIT III
(Shear Stress Distribution, Torsion of Circular Shafts and Springs)

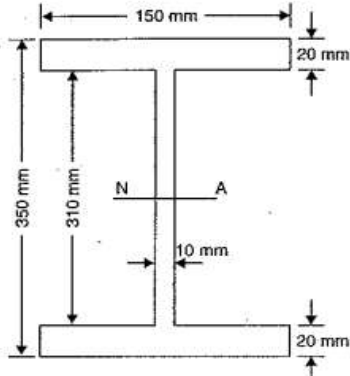
1	a) Derive shear stress distribution formula for rectangular section with a neat sketch.	L1	CO3	6M
	b) A timber beam of rectangular section is simply supported at the ends and carries a point load at the centre of the beam. The maximum bending stress is 12 N/mm^2 and maximum shearing stress is 1 N/mm^2 , find the ratio of the span to the depth.	L3	CO3	6M
2	a) Derive shear stress distribution formula for circular section with a neat sketch.	L1	CO3	6M
	b) A circular beam of 100mm diameter is subjected to a shear force of 5KN. Calculate: (i) Average shear stress (ii) Maximum shear stress (iii) Shear stress at a distance of 40mm from N.A.	L3	CO3	6M
3	Draw the shear stress distribution across: (a) Rectangular section. (b) Triangular section. (c) Circular section. (d) I & T Sections	L2	CO3	12M
4	a) The shear force acting on a beam at a section is F. The section of the beam is triangular base B and of an altitude H. The beam is placed with its base horizontal. Find the maximum shear stress and the shear stress at the N.A.	L2	CO3	8M
	b) An I-section beam 350 mm x 150 mm has a web thickness of 10 mm and a flange thickness of 20 mm. If the shear force acting on the section is 40 KN, find the maximum shear stress developed in the I-section.	L3	CO3	4M
				
5	The shear force acting on a section of a beam is 50 KN. The section of the beam is of T-shaped of dimensions 100 mm x 100 mm x 20 mm as shown in figure. The moment of inertia about the horizontal neutral axis is $314.221 \times 10^4 \text{ mm}^4$. Calculate the shear stress at the neutral axis and at the junction of the web and the flange.	L2	CO3	12M

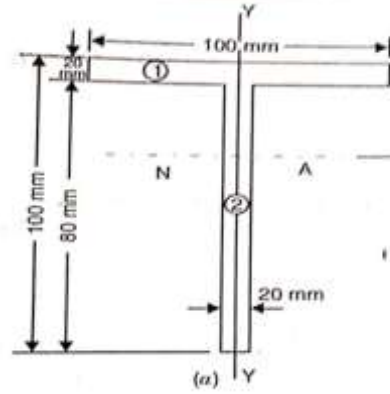

6	Derive pure torsion equation for a circular shaft with assumptions.	L2	CO3	12M
7	(a) State the difference between twisting moment and bending moment. (b) A solid steel shaft has to transmit 75 KW at 200 r.p.m. Taking allowable shear stress as 70 N/mm ² , find suitable diameter for the shaft, if the maximum torque transmitted at each revolution exceeds the mean by 30%.	L1	CO3	4M
		L3	CO3	8M
8	The stiffness of a close-coiled helical spring is 1.5 N/mm of compression under a maximum load of 60 N. The maximum shearing stress produced in the wire of the spring is 125 N/mm ² . The solid length of the spring (when the coils are touching) is given as 5 cm. Find : (i) The diameter of wire, (ii) Mean diameter of the coils and (iii) Number of coils required. Take $C = 4.5 \times 10^4$ N/mm ² .	L3	CO3	12M
9	A hollow shaft, having an inside diameter 60% of its outer diameter, is to replace a solid shaft transmitting the same power at the same speed. Calculate the percentage saving in material, if the material to be used is also the same.	L3	CO3	12M
10	A closely coiled helical spring made of 10 mm diameter steel wire has 15 coils of 100 mm mean diameter. The spring is subjected to an axial load of 100 N. Calculate : (i) The maximum shear stress induced, (ii) The deflection, and (iii) Stiffness of the spring. Take modulus of rigidity, $C = 8.16 \times 10^4$ N/mm ²	L3	CO3	12M

UNIT IV

(Deflection of Beams and Columns)

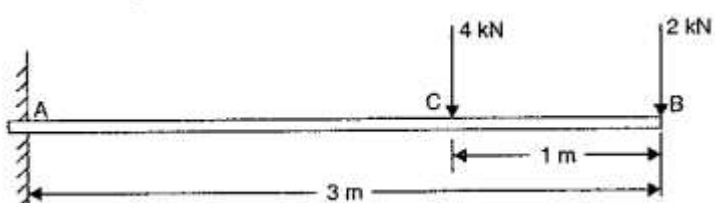
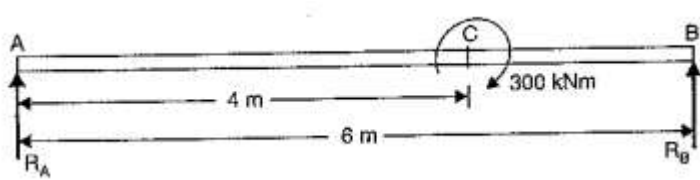
1	Derive the relation between slope, deflection and radius of curvature.	L2	CO4	12M
2	A beam of uniform rectangular section 200 mm wide and 300 mm deep is simply supported at its ends. It carries a uniformly distributed load of 9 KN/m run over the entire span of 5 m. If the value of E for the beam material is $1 \times 10^4 \text{ N/mm}^2$, find : (i) The slope at the supports and (ii) Maximum deflection.	L3	CO4	12M
3	Determine: (i) slope at the left support, (ii) deflection under the load and (iii) maximum deflection of a simply supported beam of length 5 m, which is carrying a point load of 5 KN at a distance of 3 m from the left end. Take $E = 2 \times 10^5 \text{ N/mm}^2$ and $I = 1 \times 10^8 \text{ mm}^4$.	L3	CO4	12M
4	A cantilever of length 3 m carries two point loads of 2 KN at the free end and 4 KN at a distance of 1 m from the free end. Find the deflection at the free end. Take $E = 2 \times 10^5 \text{ N/mm}^2$ and $I = 10^8 \text{ mm}^4$	L3	CO4	12M
				
5	A horizontal beam AB is simply supported at A and B, 6 m apart. The beam is subjected to a clockwise couple of 300 KNm at a distance of 4 m from the left end as shown in figure below. If $E = 2 \times 10^5 \text{ N/mm}^2$ and $I = 2 \times 10^8 \text{ mm}^4$, determine : (i) Deflection at the point where couple is acting and (ii) The maximum deflection.	L3	CO4	12M
				
6	(a) Write the assumptions made in the Euler's column theory. (b) Write the end conditions for long columns and state the difference between long columns and short columns.	L2	CO5	4M
		L2	CO5	8M
7	Derive an expression for crippling load when both ends of the column are hinged.	L2	CO5	12M
8	A solid round bar 3 m long and 5 cm in diameter is used as a strut with both ends hinged. (Take $E = 2.0 \times 10^5 \text{ N/mm}^2$) Determine the crippling load, when the given strut is used with the	L3	CO5	12M

	following conditions : (i) One end of the strut is fixed and the other end is free (ii) Both the ends of strut are fixed (iii) One end is fixed and other is hinged.			
9	A column of timber section 15 cm x 20 cm is 6 metre long both ends being fixed. If the Young's modulus for timber = 17.5 KN/mm^2 , determine : (i) Crippling load and (ii) Safe load for the column if factor of safety = 3.	L3	CO5	12M
10	Using Euler's formula, calculate the critical stresses for a series of struts having slenderness ratio of 40, 80, 120, 160 and 200 under the following conditions : (i) Both ends hinged and (ii) Both ends fixed. Take $E = 2.05 \times 10^5 \text{ N/mm}^2$	L3	CO5	12M

UNIT V
(Thin Cylinders and Thick Cylinders)

1	a) Derive expression for circumferential stress in thin cylinder. b) A cylindrical pipe of diameter 1.5m and thickness 1.5cm is subjected to an internal fluid pressure of 1.2 N/mm ² . Determine: i) Longitudinal stress developed in the pipe, and ii) Circumferential stress developed in the pipe.	L2 L3	CO6 CO6	6M 6M
2	A cylindrical thin drum 80cm in diameter and 3m long has a shell thickness of 1cm. If the drum is subjected to an internal pressure of 2.5 N/mm ² , Take $E = 2 \times 10^5$ N/mm ² and Poisson's ratio 0.25 Determine (i) change in diameter (ii) change in length and (iii) Change in volume.	L3	CO6	12M
3	A cylindrical shell 100mm long 200mm internal diameter having thickness of a metal as 10mm is filled with a fluid at atmospheric pressure. If an additional 200mm ³ pumped into the cylinder, Take $E = 2 \times 10^5$ N/mm ² and Poisson's ratio is 0.3. Find (i) The pressure exerted by the fluid on the cylinder and (ii) The hoop stress induced.	L3	CO6	12M
4	A copper cylinder, 90 cm long, 40 cm external diameter and wall thickness 6 mm has its both ends closed by rigid blank flanges. It is initially full of oil at atmospheric pressure. Calculate additional volume of oil which must be pumped into it in order to raise the oil pressure to 5 N/mm ² above atmospheric pressure. For copper assume $E = 1.0 \times 10^5$ N/mm ² and Poisson's ratio 1/3. Take bulk modulus of oil as $K = 2.6 \times 10^3$ N/mm ² .	L3	CO6	12M
5	A closed cylindrical vessel made of steel plates 4 mm thick with plane end, carries fluid under a pressure of 3 N/mm ² . The dia. of cylinder is 30 cm and length is 80 cm, calculate the longitudinal and hoop stresses in the cylinder wall and determine the change in diameter, length and volume of the cylinder. Take $E = 2 \times 10^5$ N/mm ² and Poisson's ratio is 0.286	L3	CO6	12M
6	a) A cylinder of thickness 1.5cm has to withstand maximum internal pressure of 1.5N/mm ² . If the ultimate tensile stress in the material of the cylinder is 300N/mm ² , factor of safety 3.0 and joint efficiency 80%, determine the diameter of the cylinder. b) A spherical shell of internal diameter 0.9m and of thickness 10mm is subjected to an internal pressure of 1.4 N/mm ² . Determine the increase in diameter and increase in volume. Take $E = 2 \times 10^5$ N/mm ² and $\mu = 1/3$.	L3 L3	CO6 CO6	6M 6M
7	Derive an expression for hoop and radial stresses across thickness of the thick cylinder.	L2	CO6	12M
8	Determine the maximum and minimum hoop stress across the section of a pipe of 400 mm internal diameter and 100 mm thick, when the pipe contains a fluid at a pressure of 8 N/mm ² . Also sketch the radial	L3	CO6	12M

	pressure and hoop stress distribution across the section.			
9	A compound cylinder is made by shrinking a cylinder of external diameter 300 mm and internal diameter of 250 mm over another cylinder of external diameter 250 mm and internal diameter 200 mm. The radial pressure at the junction after shrinking is 8 N/mm^2 . Find the final stresses set up across the section, when the compound cylinder is subjected to an internal fluid pressure of 84.5 N/mm^2 .	L3	CO6	12M
10	A steel cylinder of 300 mm external diameter is to be shrunk to another steel cylinder of 150 mm internal diameter. After shrinking, the diameter at the junction is 250 mm and radial pressure at the common junction is 28 N/mm^2 . Find the original difference in radii at the junction. Take $E = 2 \times 10^5 \text{ N/mm}^2$.	L3	CO6	12M

PREPARED BY: Dr. F. ANAND RAJU, A. ASHA & P. TEJASRI